

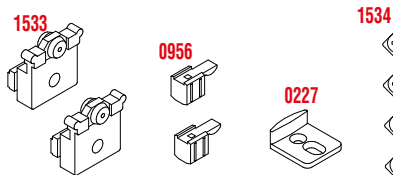

Sistemi scorrevoli per mobili / Sliding systems for furniture





KIT 1533-227 - MAX 15 KG



Legenda KIT / Kit Legend

1533	Carrello superiore per profilo 0950 <i>Upper Truck with profile 0950</i>
1534	Giunto per anta alluminio <i>Joint for aluminium door</i>
0956	Fermo superiore <i>Upper stopper</i>
0227	Scivolo inferiore <i>Lower slide</i>

Legenda altri componenti Legend other items

0950		Profilo alluminio superiore <i>Upper aluminium profile</i>
1532		Guarnizione plastica <i>Plastic gasket</i>
1531		Profilo anta alluminio laterale <i>Side aluminium door profile</i>
1530		Profilo alluminio superiore e inferiore <i>Upper and lower aluminium profile</i>

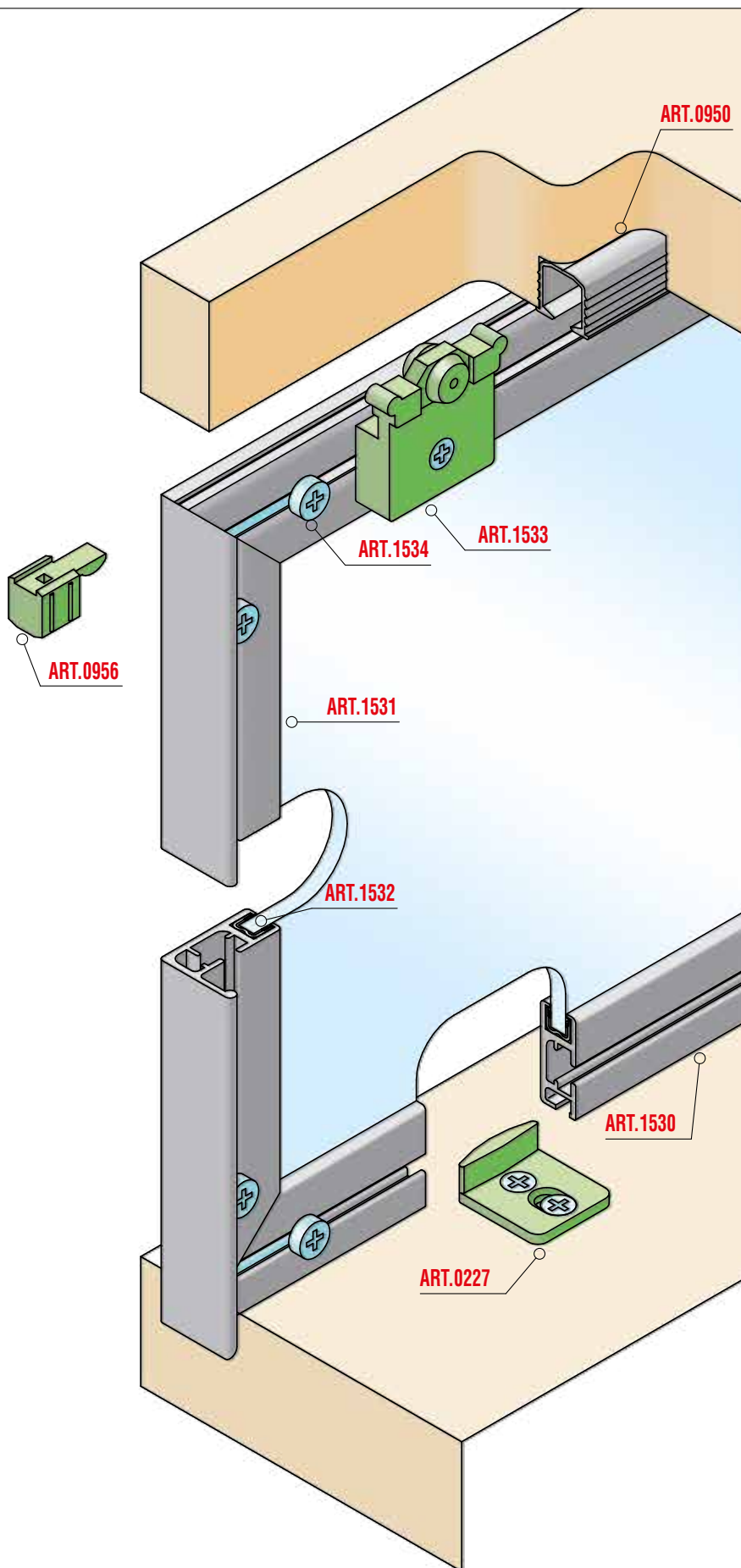

Sezione verticale / Vertical section

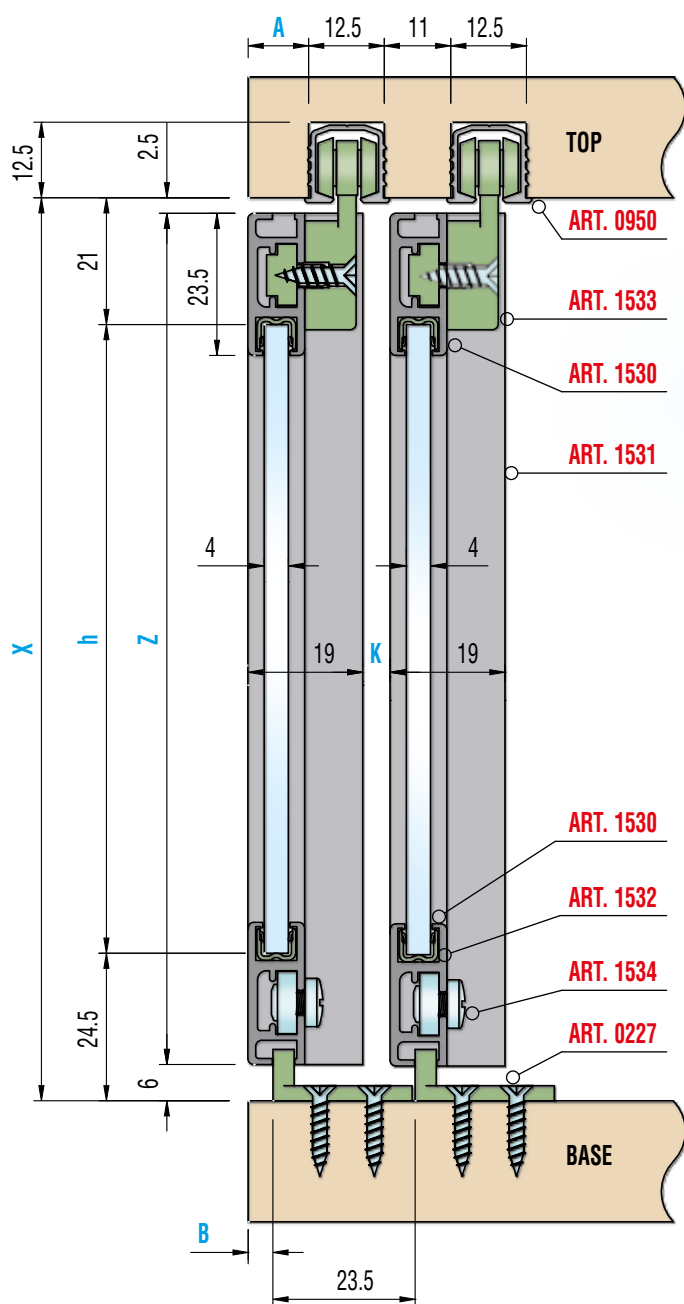

Peso massimo anta Kg. 15
Maximum door weight Kg 15

A = min. 10

Anta filo mobile A = 10 mm.

Door in line with the furniture edge A = 10 mm.

B =	A - 6
K =	4,5
h =	X - 45,5 mm. = altezza pannello X - 45,5 mm. = panel height
Z =	X - 8,5 mm. = altezza antina X - 8,5 mm. = door height

Spessore pannello = 4 mm.
Panel thickness = 4 mm.

Sormonto minimo / Minimum overlapping

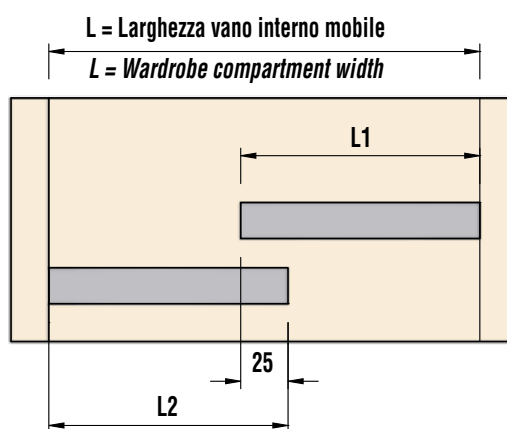

Schema montaggio carrelli / How to fit the trucks

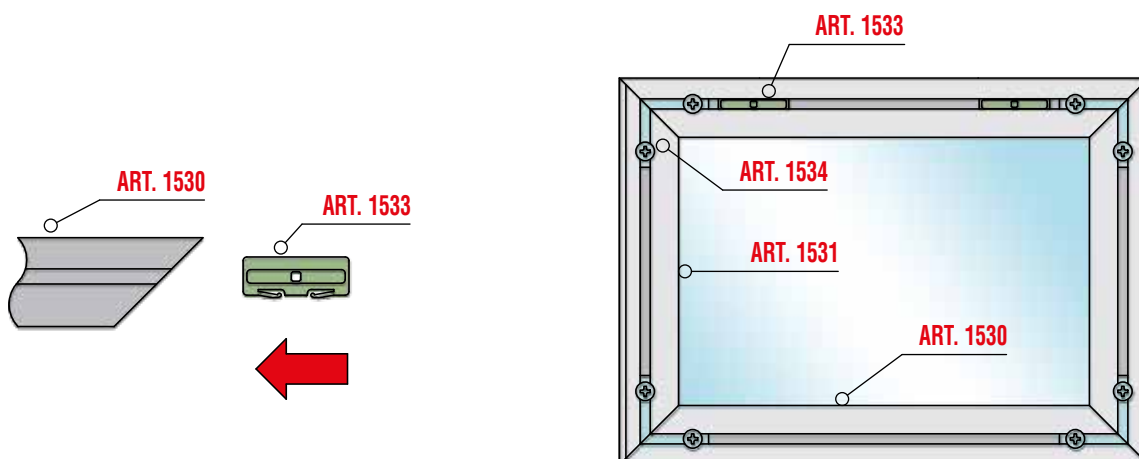



Schema di montaggio / Assembling

Montaggio ante con profilo art.0950 / How to fit the doors with art.0950

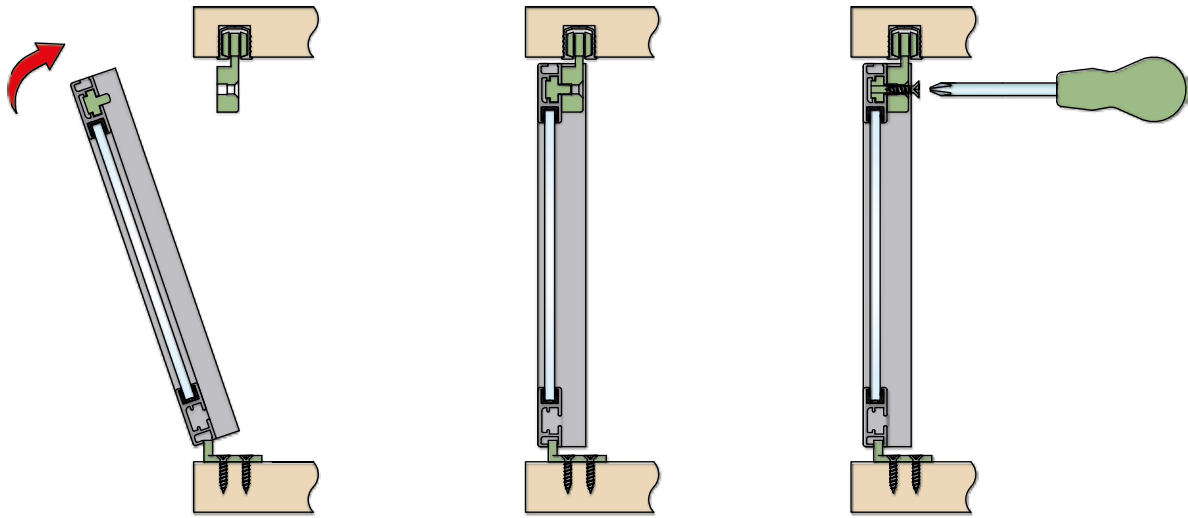

Montaggio anta alluminio / How to fit the aluminium door

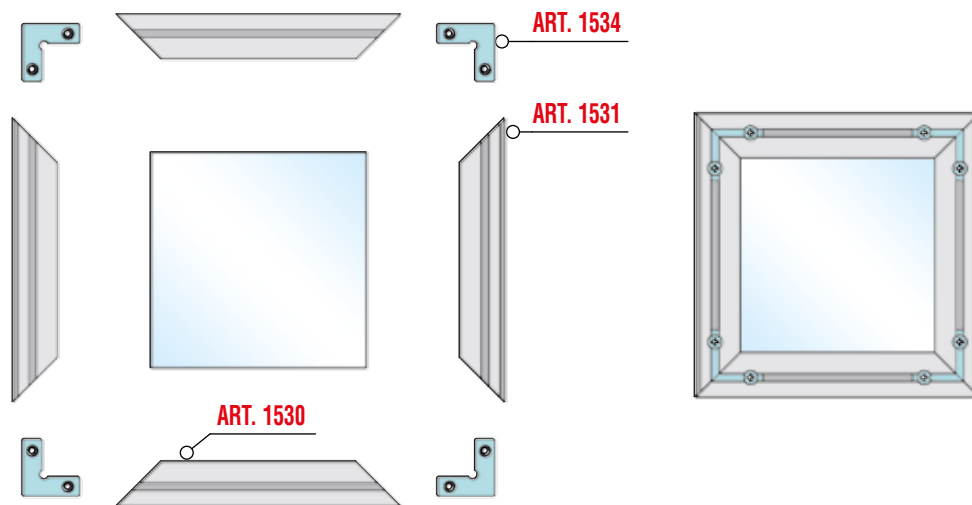

Calcolo dimensioni anta / Door size calculation

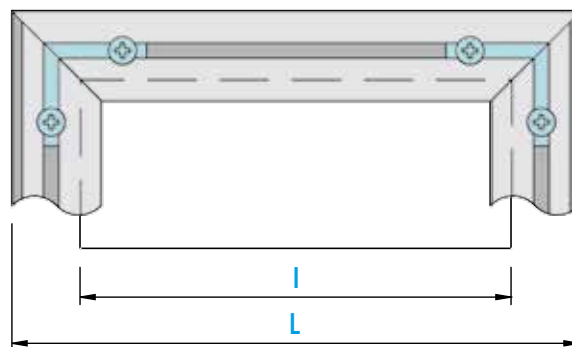

L = LARGHEZZA ANTA / DOOR LENGTH

l = LARGHEZZA PANNELLO = L - 37 mm. / PANEL LENGTH = L - 37 mm.